

◆ **Technical Data:**

Model: PR-26DC-DAI-RT-N

GENERAL SPECIFICATIONS

Timers: 1024

Counters: 1024

Function Blocks: 1024

Operation temp.: -20°C - 55°C

Storage: -40°C - 70°C

Protection: IP20 (Non-waterproof)

RTC accuracy: MAX ±2S/day

RTC Backup at 25 °C: 20 days

Program and settings Backup: 10 years

Data Power-off retentivity: 10 years

Modify parameters via keypad LCD: YES

Dimensions: 133*90*60 (Unit: mm)

Certificate: CE

Installation: 35-DIN rail or screw for installation

Expansion capacity: 16 modules (PR-E-16)

Password protection: 4-digit number password protection or disable program upload function

Communication interface: 1 RS232 port (COM0), 3 RS485 port (COM2, COM3 built-in, COM1 external)
1 Ethernet port

Communication protocol: Modbus RTU/ASCII, Modbus TCP

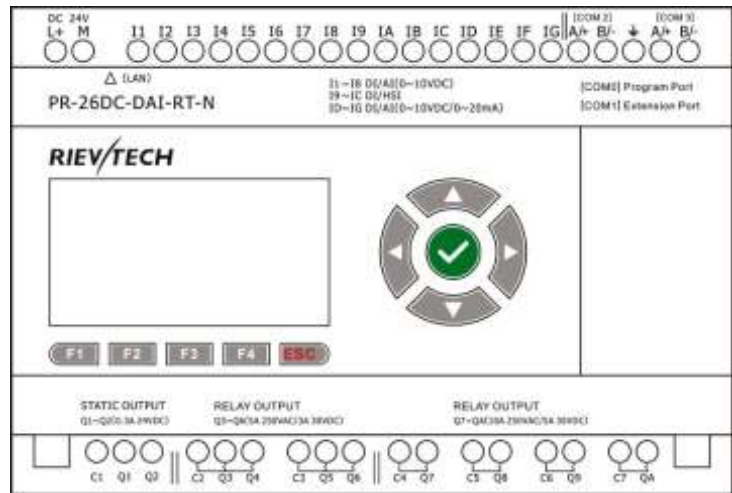

Technical Index

Power supply:	
Nominal voltage	DC 24V
Operating limits	DC 20.4-28.8V
Immunity from micro power cuts	Typ.5 ms
Max. Startup current	Max. 0.3A
Max. absorbed power	10W
Protection against polarity inversions	Yes
Input parameters:	
Input No	16 (I1-IG)
Digital input	16 (I1-IG)
Analogue input	8 (I1-I8) (0...10V DC) +4(ID-IG) (0...20mA OR 0...10V DC)
Digital input and Analogue inputs (0...10V)10-bits (I1-I8)	
Inputs used as digital inputs (I1-I8)	
Input voltage	DC 0 - 28.8V
Input signal0	< 5V DC; <0.08mA
Input signal1	> 8 V DC; >0.12mA
Input current	0.16mA @ 10.8V dc 0.18mA @ 12.0 V dc

	0.34mA @ 24 V dc 0.41mA @ 28.8 V dc
Response time	0 to 1 : Typ. 10.5 ms ; 1 to 0 : Typ. 1.5 ms
Maximum counting frequency	Typ.: 4 HZ
Sensor type	Contact or 3-wire PNP
Input type	Resistive
Isolation between power supply and inputs	None
Isolation between inputs	None
Inputs used as Analogue inputs (0...10V) (I1-I8)	
Measurement range	DC 0---10V
Input impedance	Min, 24K Ω ; Max. 72K Ω
Input voltage	28.8 V DC max
Resolution	10bit ,0.01V
Accuracy at 25 °C	\pm (Max. 0.02) V
Accuracy at 55 °C	\pm (Max. 0.04) V
Isolation between analog channel and power supply	None
Cable length	10 m max. shielded and twisted
Digital and high-speed inputs (I9--IC)	
Digital inputs (I9-IC)	
Input voltage	DC0-28.8V
Input signal0	< 5V DC; <1mA
Input signal1	> 8 V DC;>1.6mA
Input current	2.1mA @ 10.8V dc 2.3mA @ 12.0 V dc 4.6 mA @ 24 V dc 5.5 mA @ 28.8 V dc
Response time	0 to 1 : <1 ms ; 1 to 0 : <1 ms
High speed inputs (I9-IC)	
Maximum counting frequency	60kHz (I9--IC)
Digital and Analogue (0...10V) & Analogue (0...20mA) (ID-IG)	
Inputs used as digital inputs (ID-IG)	
Input voltage	DC 0-28.8V
Input signal0	< 5V DC;<0.08mA
Input signal1	> 8 V DC;>0.12mA
Input current	0.16mA @ 10.8V dc 0.18mA @ 12.0 V dc 0.34mA @ 24 V dc 0.41mA @ 28.8 V dc
Response time	0 to 1 : Typ. 10.5 ms ; 1 to 0 : Typ. 1.5 ms
Maximum counting frequency	Typ.: 4 HZ
Sensor type	Contact or 3-wire PNP
Input type	Resistive
Isolation between power supply and inputs	None

Isolation between inputs	None
Inputs used as Analogue inputs (0...10V) (ID-IG)	
Measurement range	DC 0---10V
Input impedance	Min, 24K Ω ; Max. 72K Ω
Input voltage	28.8 V DC max
Resolution	10bit ,0.01V
Accuracy at 25 °C	\pm (Max. 0.02) V
Accuracy at 55 °C	\pm (Max. 0.04) V
Isolation between analogue channel and power supply	None
Cable length	10 m max. shielded and twisted
Input signal0	< 5V DC; <0.08mA
Input signal1	> 8 V DC; >0.12mA
Input current	0.16mA @ 10.8V dc 0.18mA @ 12.0 V dc 0.34mA @ 24 V dc 0.41mA @ 28.8 V dc
Response time	0 to 1 : Typ. 10.5 ms ; 1 to 0 : Typ. 1.5 ms
Sensor type	Contact or 3-wire PNP
Input type	Resistive
Isolation between power supply and inputs	None
Isolation between inputs	None
Inputs used as Analogue inputs (0...20mA) (ID-IG)	
Analogue signal	0/4....20mA current
Input impedance	260 Ω
Resolution	0.02mA
Accuracy at 25 °C	0.05mA
Cycle time for analogue value generation	Typ. 50 ms
Protection against polarity inversions	yes
Overvoltage protection	Yes, if the input voltage is >6.5V, this one is automatically switched on 0--10V configuration
Isolation between power supply and inputs	No
Cable length	<=30M with shielded twisted cable (sensor not isolated)
Output	
Digital/Transistor output (PNP) - Q1...Q2	
Breaking voltage	DC 5--30V
Nominal voltage	\leq Supply voltage
Nominal current	Max. 0.3 A per channel
Max. breaking current	0.65 A
Voltage drop	< 2 V for I = 0.3 A (at state 1)
Response time	Make \leq 1 ms Release \leq 1 ms
Frequency (Hz)	resistive load: 10 Hz inductive load: 0.5 Hz

Built-in protections	Against overloads and short-circuits: No Against overvoltage (*): No
Galvanic isolation	None
PWM frequency	10kHz
PWM cyclic ratio	0 to 100 %
PWM accuracy at 120Hz	< 0.5 % (20 % → 80 %) load at 10 mA
Max. Breaking current PWM	50 mA
Max. cable length PWM	20m
5A Relay 4 outputs from Q3 to Q6	
Max. breaking voltage	CE:AC 250 V/DC 30 V 5A UL:AC 250 V/DC 30 V 3A
Electrical durability Expectancy	10 ⁵ Operations at Rated Resistive Load
Mechanical life	10 ⁷ Operations at No Load condition
Response time	Operate Time: 15 mS Max. Release Time: 10 mS Max.
Built-in protections	Against short-circuits: None Against overvoltage and overloads: None
10A Relay 4 outputs from Q7 to QA	
Max. breaking voltage	CE:AC 250 V/DC 30 V 10A UL:AC 250 V/DC 28 V 5A
Max. Allowable Power Force	1250VA
Electrical durability Expectancy	10 ⁵ Operations at Rated Resistive Load
Mechanical life	10 ⁷ Operations at No Load condition
Response time	Operate Time: 15 mS Max. Release Time: 10 mS Max.
Built-in protections	Against short-circuits: None Against overvoltage and overloads: None
Communication ports parameters:	
COM0_TTL port	Can be used as programming port with PR-RS232 & PR-USB cables. Can be converted to RS232 port with PR-RS232 cable. Can be converted to RS485 port with PRO-RS485 cable. Note: Remove expansion cover to use. Can be used as Modbus Master or Slave
Built-in RS485 COM2	1 built-in RS485 port (Terminal A+, B-) Can be used as Modbus Master or Slave
Built-in RS485 COM3	1 built-in RS485 port (Terminal A+, B-) Can be used as Modbus Master or Slave
Ext RS485 COM1	Need to use PR-E-RS485 module Can be used as Modbus Master or Slave
Ethernet port:	Built-In(10M/100M), 1.Can be used as program or communication 2.Can be used as Modbus Master or Slave
Monitoring webserver page	Yes
xLogic <---> xLogic (by Ethernet)	When xLogic works as a TCP server, it can connect with up to 8 TCP clients (xLogic or other TCP devices).

xLogic <--> Ethernet/Internet:	When xLogic works as a TCP client, it can connect with up to 8 different TCP servers
Other parameter	
Weight	Approx.400g

Dimension and wiring

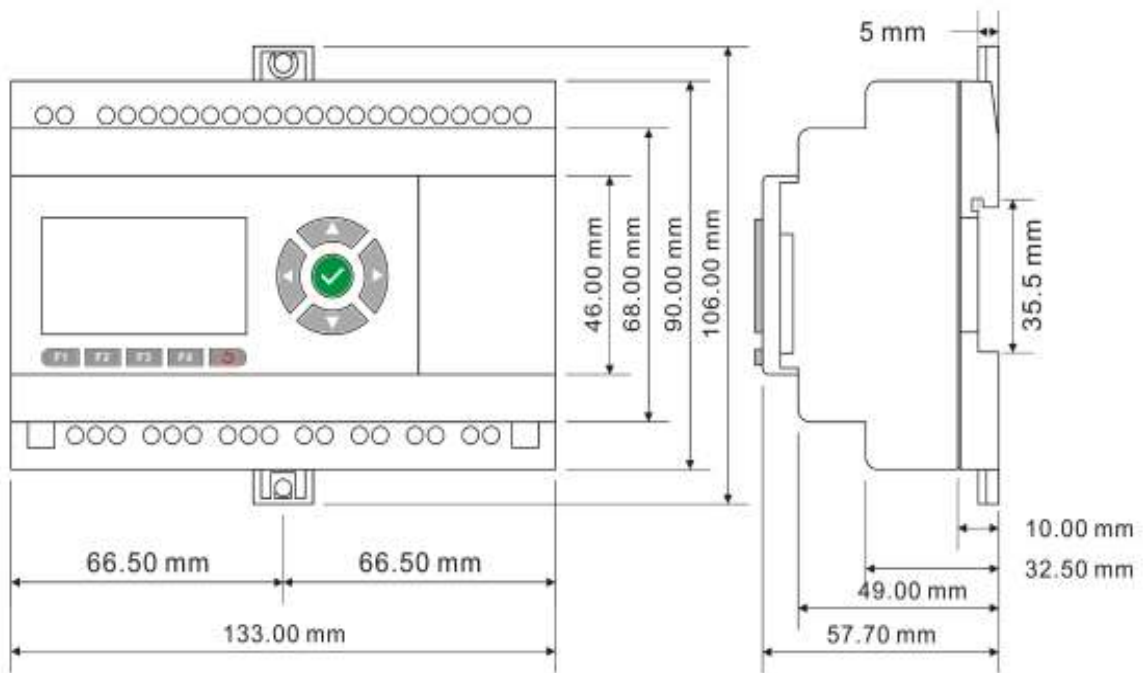

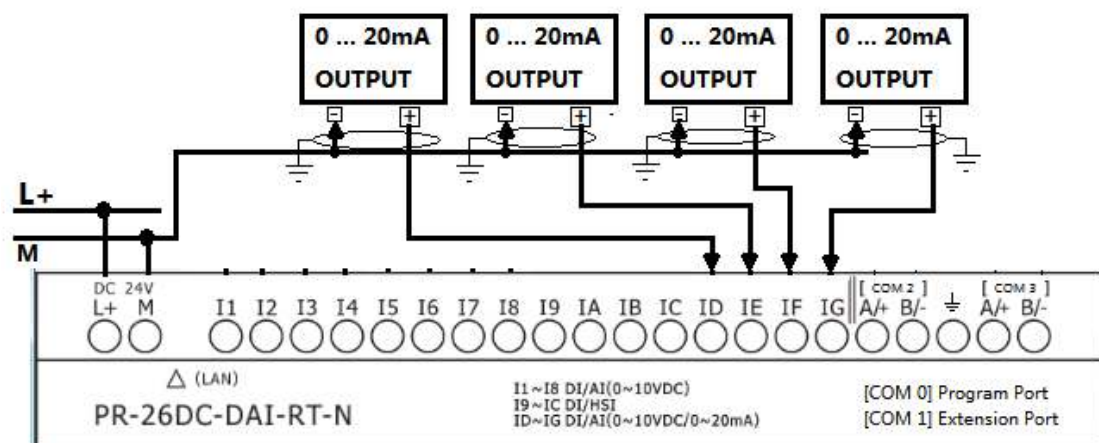
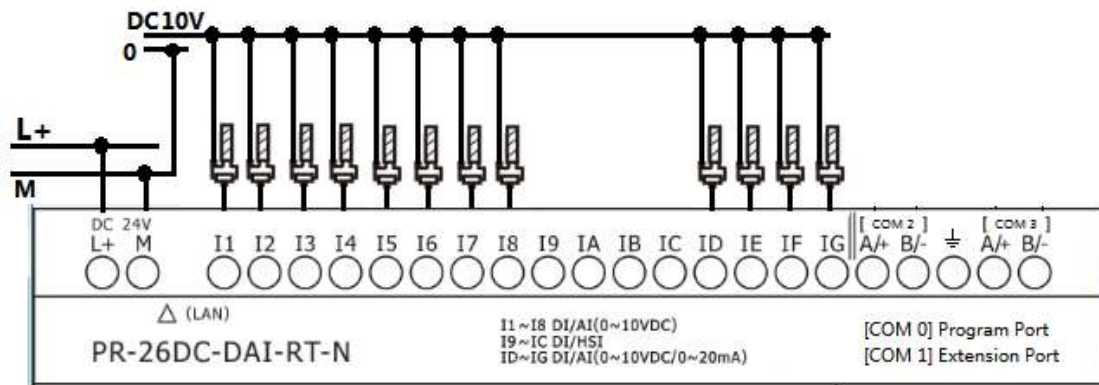
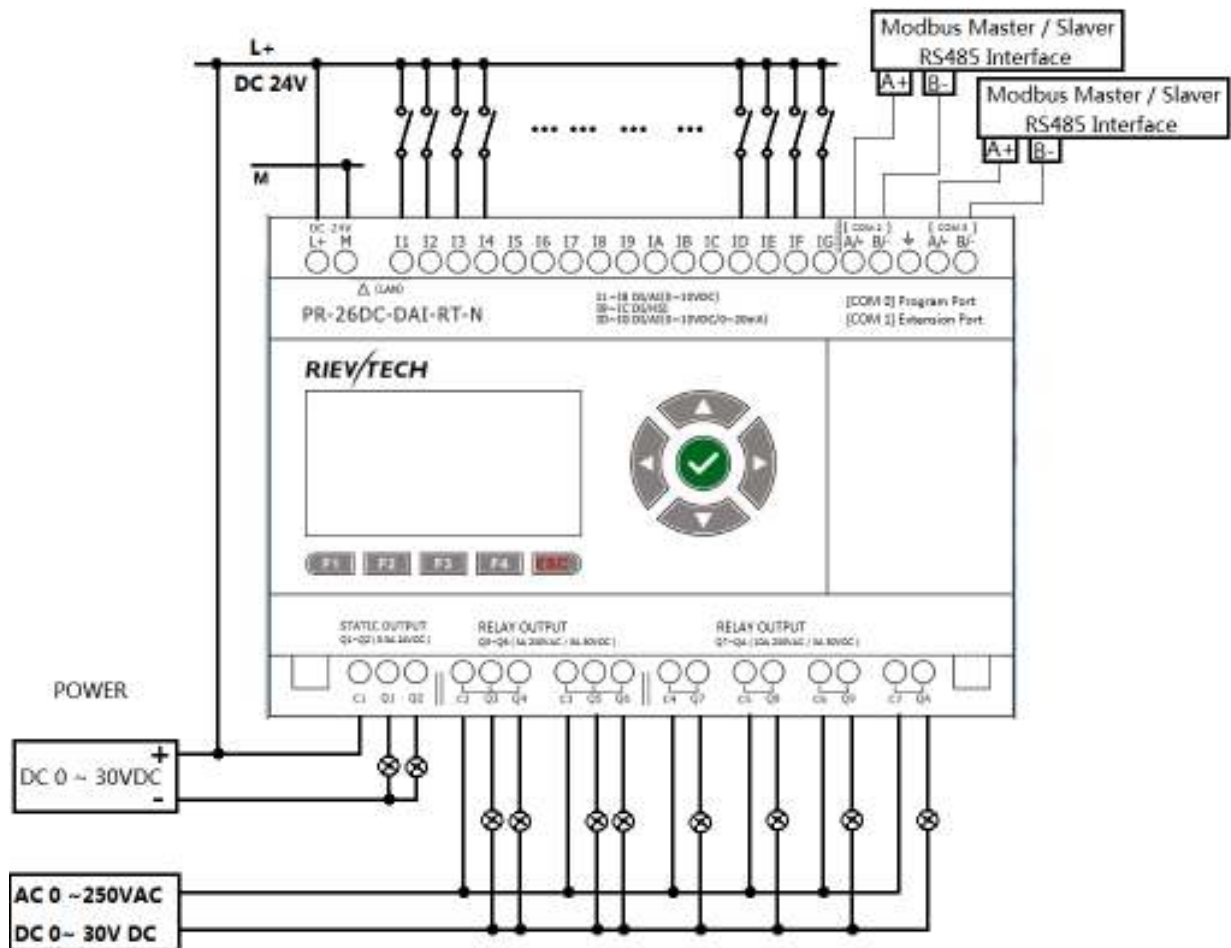

SYSTEM	Operating System requirements	Windows /2000/XP/WIN7/WIN8			
	Programming languages	Function block			
	Program Memory	1024			
	Execution Speed	<0.1ms per function			
	LCD Display	4 lines x 16 characters			
	Functions	Up to 70 function blocks			
BASIC	Timers				a. On-delay; b. Off-delay etc. Up to 12 types of timers
	Maximum Number	1024			
	Timing Ranges	10ms--99 h59m			
	Counters				a. Up/down Counter b. Hours Counter c. Frequency Threshold Trigger
	Maximum Number	1024			
	Highest Count	99999999			
	Resolution	1			
	RTC				a. Weekly Timer b. Yearly Timer
	Number available	1024			
	Resolution	1 min			
	Time span available	Week/year-month-day-hour-min			
	Flags				a. Digital Flag b. Analogue Flag
	Digital flags	256			
	Analogue flags	256			
	PI Functions				a. PI Controller
	Number available	30			
	Parameter Ranges	1-32767			
	Analogue Math				a. Analogue Math b. Analogue Math Error detection
	Number available	1024			
	Function	Add, Subtract, Multiply, Divide			
Analogue Ramp Function				a. Analogue Ramp	
Number available	55				
Compare Function				a. Analogue compactor b. Comparison of 2 values	
Number available	1024				
Special Functions	HMI Screens				a. Message texts
	Number available	128			
	Display/Edit	Preset Current value and Free text			
	PWM Functions				a. PWM
	Number available	1024 (2 fast outputs for Transistor)			
	Communication Functions				a. Modbus write b. Modbus read
	Number available	1024 (Only when CPU works as Modbus Master are these blocks required. As a Slave none are needed.)			
	Word/bit data Conversion	Square Boot	Sin/Cos	RS latch relay	
	Data-logger Function	Analog watchdog	Analog filter	Average value	

	Pumps Management	Defrost function	Multiplexer	Pulse Relay
	Cam Control	Astronomical clock	Stopwatch	Boolean function
Note: 1. Not all program functions are listed in this table i.e. AND, NAND, OR, NOT, NOR, XOR, SHIFT REGISTER, DATA LATCHING RELAY, COMPORT STATUS etc.				

www.rievtech.com

www.rievtech.co.uk